

Telepak Industries

Splice & Seal

Pedestal Sealing Kit

A new and Economical method to seal wire work in above ground pedestal closures including the "Cool Peds."

Ped-Seal can be used on new construction or on existing rehab situations in most "butt-splice" configurations.

Can be used on any PIC Cable, filled or air core, up to 600pr considering the variable involving connector type and splice diameter (max 5".)

Provides protection from UV, insects, rodents and moisture/water intrusion.

TPI-PED SEAL KIT

Contents:

<u>Quantity</u>	<u>Part Number</u>	<u>Description</u>
1 Roll	TPI220-SS	Sealant Strip Material
10 Each	TPI-PB30	Poly Protective Bag
20 Each	TPICT-14W	Wide Cable Tie 14" long
1 Roll	TPIMB-18	Moisture Barrier 18" x 20'
10 Each	TPI-W	Cleaning Wipe
1 Each		Instruction Sheet



Telepak Industries

1505 Northwest 30th Street

Faribault, Minnesota 55021

(PH) 507-332-0012 (FAX) 507-334-5895

TPI Ped Seal™ System (Kit)

The TPI *Ped Seal™* System is designed to seal wire work in various configurations contained in new or existing above ground pedestals. It will provide an environmental seal against U.V., (UVI / UVA 10% UV944 hindered amine light stabilizer), insect/rodent and moisture/water intrusion. It can be used for all PIC cable, filled or air-core.

Materials Included in Kit:

TPI220-SS	(1)	SEALANT STRIPS
TPI-PB30	(10) ea	POLY PROTECTIVE BAGS
TPIMB-18	(1) roll	ROLL ALUMINUM MOISTURE BARRIER
TPICT-14W	(20) ea	14" H.D. CABLE TIES
TPI-W	(10) ea	CLEANING WIPES
	(1)	INSTRUCTIONS

Installation Steps, Wire Work:

1. Open Cables and install bonding hardware according to local policy.
2. Thoroughly clean cable/service wires/terminal stubs with the wipes provided, from bond clamp to at least 6 inches below.
3. Complete wire work following local policies.
4. Wrap wire work with Clear Wrap. The bundle may be covered with Aluminum Moisture Barrier if local policy requires.
5. Prepare any terminal stubs, service or ground wires per figure 1.

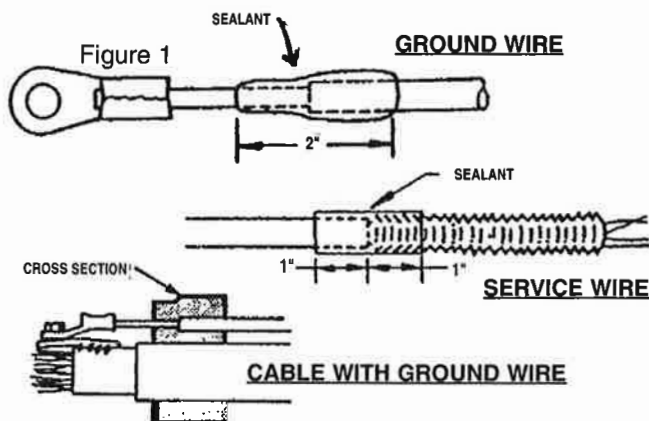

6. Wrap two layers of TPI220-SS Sealant Strips directly below bond clamps and press cables firmly together.

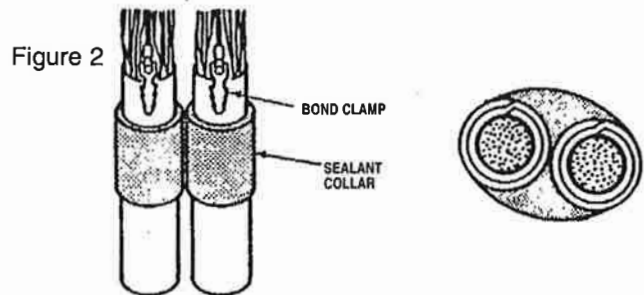

7. Cut and roll 2-inch strips of Sealant. Align and press them into the crotches between wire, cable and Sealant Collars.



Figure 3

8. Where no service or ground wires enter splice, place one full wrap of sealant over cables, forming to keep as concentric as possible.

- Addition of service or ground wire requires adding one full layer of sealant to form a collar for each wire. (See figure 4.)

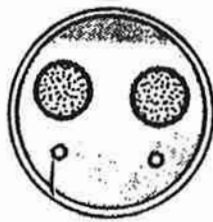

Figure 4

- Arrange and align service wire drop collars and ground wire drop collars with main cable collars.
- Fill in voids between and around the entire collar with rolled and folded pieces of sealant.

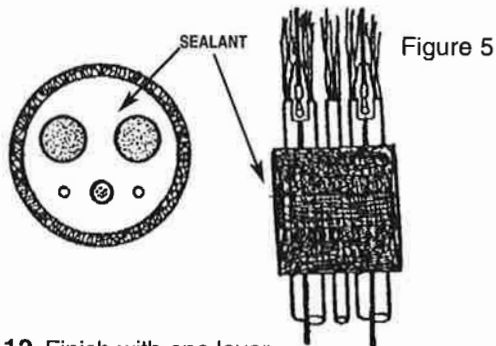

Figure 5

- Finish with one layer of Sealant Strips over entire collar again, keeping collar as concentric as possible.

NOTE: If several re-enters are anticipated the sealant Collar may be covered with several wraps of clear wrap.

- Pull black poly protective bag over the splice bundle.
- Using two cable ties cinch the bag over the sealant collar. Tighten the ties so they create only a slight 1/8 inch depression in the collar.
- Completed installation can be dressed by folding over any excess slack, securing with vinyl tape and removing any excess below sealing collar.

Re-entry Ped Seal:

- Cut cable ties and remove bag.
- Complete repair or rearrangements.
- Repeat following steps 13-15.

NOTE: If Sealant Collar becomes deformed after several re-entries, add an additional wrap of sealant over collar. Repeat Steps 13-15.

Remember!
 There is no job so important
 that we cannot take the time
 to perform our work
SAFELY!

WARRANTY: Telepak Industries (TPI) sells its products knowing the user will evaluate and determine the suitability for the intended application. You assume all risks and liability associated with such use. All Telepak Industries cable products are warranted to be free from all defects in material and workmanship at the time of sale. Our obligation under this warranty is limited to, at our option, to replace or reimburse for any product proved defective within 2 years from the date of delivery. Proof of purchase is required.

INSTALLATION PRACTICE WAS AMMENDED TO REFLECT SPECIFIC QWEST COMMUNICATIONS, PROCEDURES AND NOMENCLATURE.

Limited Liability and Exclusions: TPI MAKES NO OTHER WARRANTIES INCLUDING, BUT NOT LIMITED TO, ANY IMPLIED WARRANTY OF MERCHANTABILITY OR FITNESS FOR A PARTICULAR PURPOSE. TPI WILL NOT BE LIABLE FOR ANY LOSS OR DAMAGE FROM USE OF THESE PRODUCTS WHETHER DIRECT, INDIRECT, SPECIAL, INCIDENTAL OR CONSEQUENTIAL REGARDLESS OF LEGAL THEORY ASSERTED.



Telepak Industries
 1505 Northwest 30th Street
 Faribault, Minnesota 55021
 (PH) 800-324-3314 • (Fax) 507-334-5895